

NEOPRENE SEAL MANUFACTURED TO ASTM C-923 REQUIREMENTS INSTALLED BY MANUFACTURER DURING BASE FABRICATION (TYP.)

PLAN

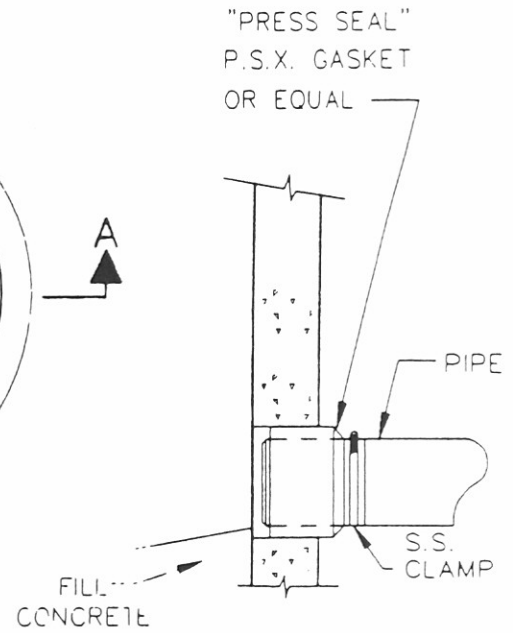

ALTERNATE GASKET

NOTES:

1. FOR ADDITIONAL MANHOLE DETAILS, SEE SD-119.
2. ALL CHANNELS AND SLOPES TO BE HAND FORMED PRIOR TO INSTALLATION OF MANHOLE.
3. INVERT CHANNEL GRADES NOT TO EXCEED GRADES ON ENTERING AND EXITING PIPE RUNS.

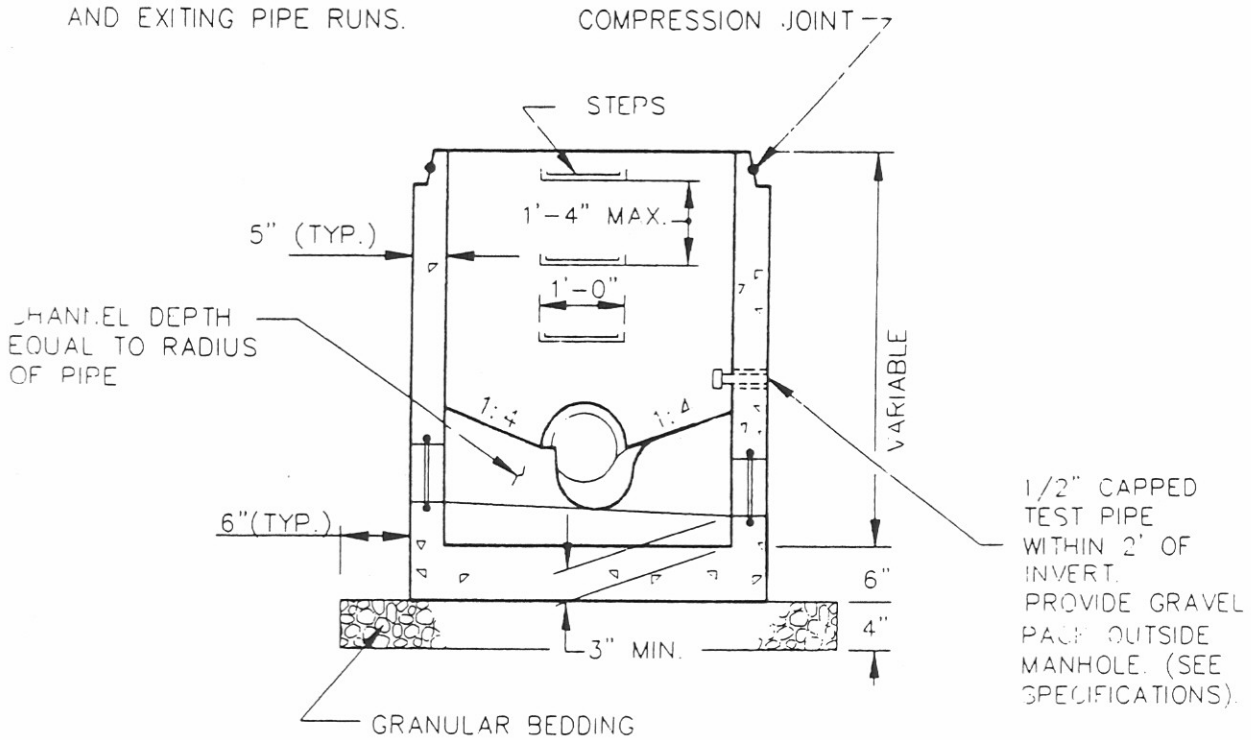

SECTION A-A

CITY OF NEW PHILADELPHIA	STANDARD CONSTRUCTION DRAWING NO
PRECAST MONOLITHIC CONCRETE MANHOLE BASE DETAIL	SD-121
	REV 1-94